

INSTALLATION AND OPERATION MANUAL





INSTALLING A SONIHULL SYSTEM

Congratulations on your purchase of the Sonihull Ultrasonic Antifouling System.

This manual provides simple installation instructions for your Sonihull control panel and Sonihull transducers. The number of units you require will depend on the size and construction of the vessel or equipment that you are protecting from marine biofouling. For advice about your specific installation please contact your local Sonihull sales representative or email us at info@nrgmarine.com.

Sonihull is suitable for use on all materials that transmit ultrasound well, including FRP, GRP, aluminium, steel, stainless-steel, titanium and rigid plastic constructions, where the transducer can be bonded to the dry side of the material that you are protecting. If your vessel construction is a FRP or GRP sandwich (two rigid surfaces with a foam core), we strongly recommend using the services of a professional marine technician, as fitting a transducer to the outer skin will involve cutting through the inner skin and removing some of the sandwich core filling to bond with the dry side of the outer skin.

Please note that the Sonihull system is not suitable for wooden boats, because wood is a poor transmitter of ultrasonic sound frequencies.

For Ferro-cement hulls it is recommended that you double the number of transducers required compared to the illustration in this brochure to achieve the best results.

SAFETY INSTRUCTIONS

We recommended that the electrical installation of this system is carried out by a qualified marine electrician.

When mounting the control box, please find a suitable dry position, above the water line where possible. Connect all AC connections in accordance with IEC wiring regulations, ensuring the correct plug and socket are used. If connecting to a DC supply, ensure the device is wired directly via a 5 Amp breaker.

Colour codes for mains cable are as follows;

Brown	=	Live
Blue	=	Neutral
Green & Yellow	=	Earth

(If connected to DC supply please ensure that an in-line 5 Amp fuse is used)

IF IN DOUBT, CONTACT A PROFESSIONAL MARINE ELECTRICIAN

SONIHULL

Ultrasonic Anti-foul Protection

SONIHULL AT A GLANCE

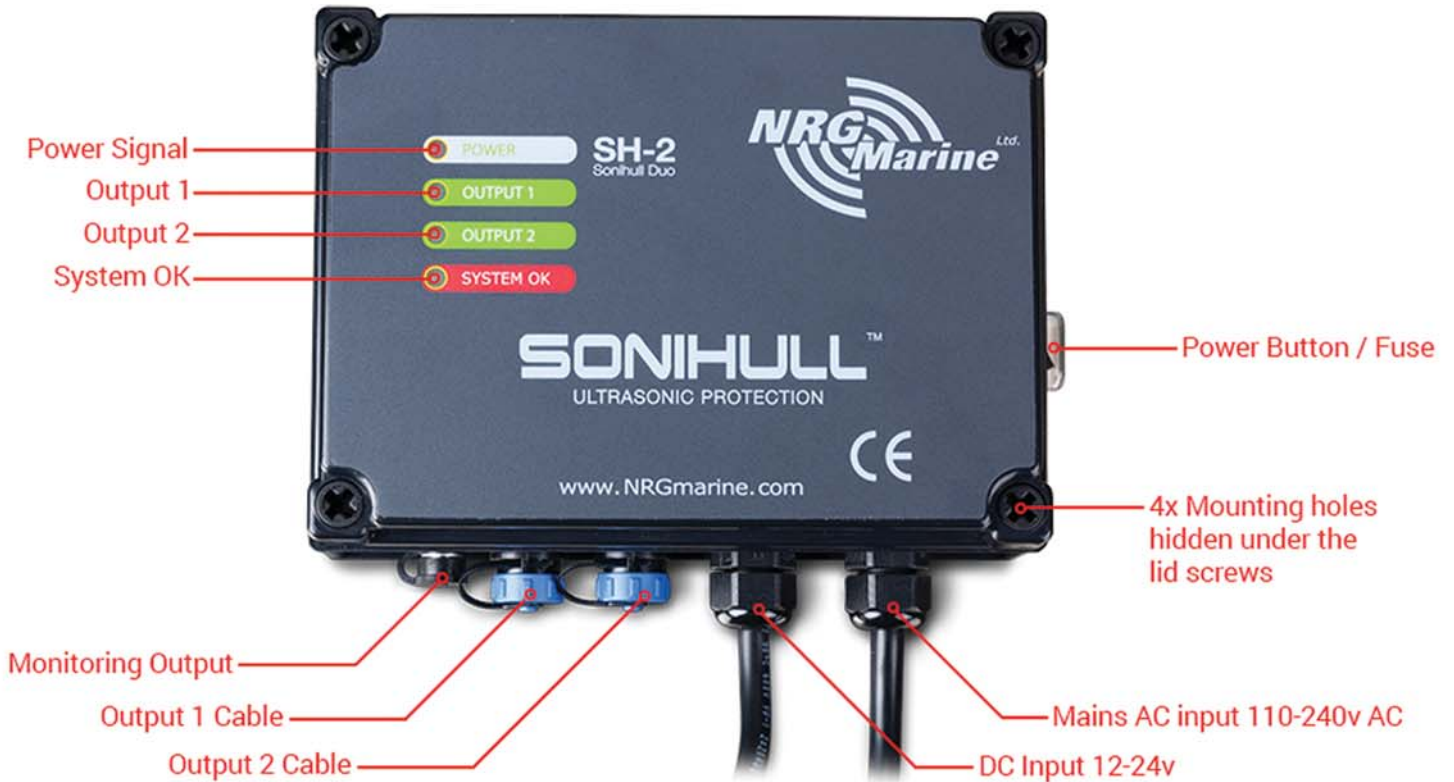

LED	COLOUR	NORMAL STATUS	FAULT STATUS	COMMENTS
Power on	Red	ON	Flashing	Flashing is normally due to incorrectly seated transducers.
Output 1	Green	ON	OFF	OFF when not connected or in fault.
Output 2	Green	ON	OFF	OFF when not connected or in fault.
System OK	Green	ON	OFF	Fault indication, check power & transducers.

Status output 3 core connector providing +5VDC output per channel in normal condition, and 0V in fault condition.



Transducer



Cable



Transducer Ring



Monitoring Plug

COMPONENTS INCLUDED

Sonihull Duo

- Sonihull ultrasonic pulse generator control unit with two transducer outputs
- Ultrasonic transducer complete with 6.5 metres of cable x 2
- Mains cable with 3 pin UK standard fused plug
- Marine Grade epoxy glue
- Petroleum jelly

Items required but not supplied with the Sonihull kit:

- 4x screws for mounting control box



TECHNICAL SPECIFICATION

MONO & DUO

Power Supply Approvals	UL and CE
Voltage	100-240V AC 50/60Hz or 12-24V DC
Power Consumption	
Sonihull Mono	3.6 Watts
Sonihull Duo	7.2 Watts

ULTRASONIC GENERATOR

Pulse Frequency	19.5 kHz - 55 kHz
IP Ratings	
Control Box Rating	IP65
Transducer Rating	IP68
Transducer Cable Length	6.5 metres
Weight:	4 Kg
Dimensions	175mm x 130mm x 75mm
Warranty:	2 years

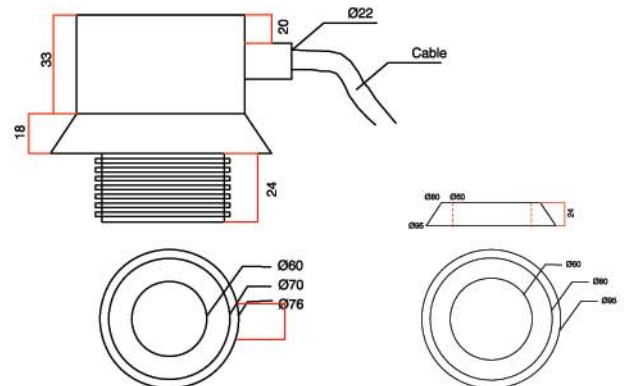
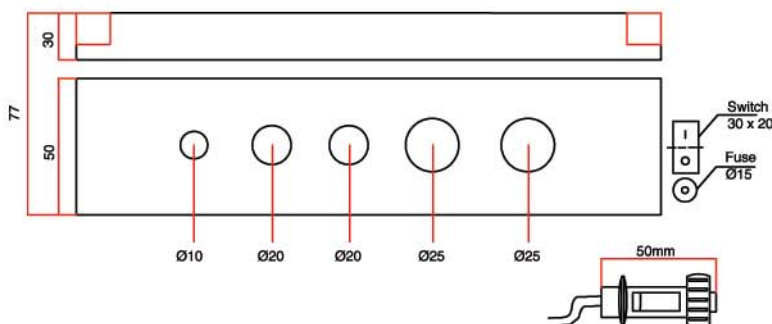
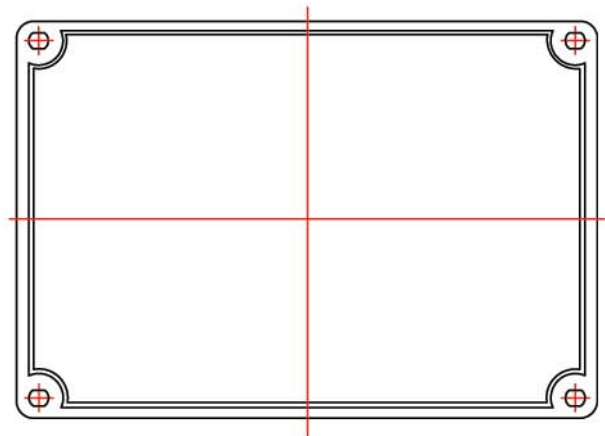
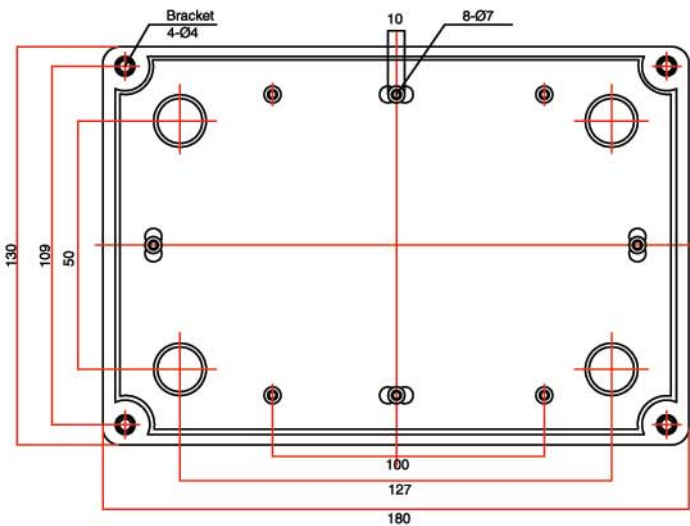

SONIHULL CONTROL UNIT



LOCATION & INSTALLATION

The Sonihull system requires little maintenance once installed, thus the control panel can be fitted out-of-sight, in a cabinet, cupboard or even in the engine room itself.

Find a suitable dry location above the water line, with suitable access to either mains or DC power.

Please also consider that the location should be suitable for cable access to the transducers. Mains AC supply 100-240 Volts AC, 50/60 Hz. DC supply, 12-24 Volts DC. (Ensure correct polarity. Ensure cables are supplied via a 5 amp in-line fuse.)

To mount the control unit, remove the lid to expose the four mounting holes and screw into place.

Replace the lid and plug the control unit into a suitable AC socket. If a socket is not available, please consult a competent marine electrician to carry out the electrical installation.

Once installed, the system should be periodically checked to ensure that it is powered and working correctly.

SONIHULL TRANSDUCER LOCATION

Once you have found a suitable location for the mounting of the transducer, ensure that there will be enough clearance above the transducer to replace any floor or access panels and that there is suitable access for running the cables back to the Sonihull control unit.

Prepare the hull/surface for the transducer by sanding down the area to ensure a smooth, flat, clean surface. It is important that both the hull and the transducer surfaces are flat and clean to ensure the best possible surface-to-surface contact and ultrasonic signal transmission. Clean the transducer face and contact surface to ensure there is no dust or grease.

Transducers are to be mounted directly to the dry side of the surface being protected. If the vessel is of a sandwich construction (two rigid surfaces with a foam core) please consult a professional marine technician, as fitting a transducer to the outer skin will involve cutting through the inner skin and removing some of the sandwich core filling to bond with the dry side of the outer skin.

Please also read our SONIHULL INSTALLATION TIPS on the following pages, for more advice about transducer location and installation.



TRANSDUCER POSITIONING – BY VESSEL TYPE

SAILING YACHT

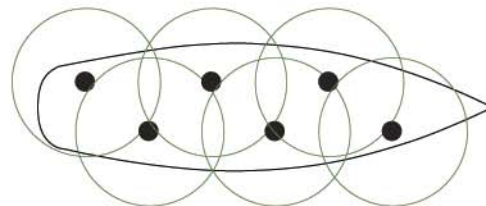
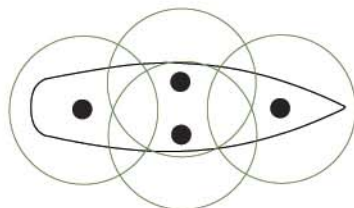
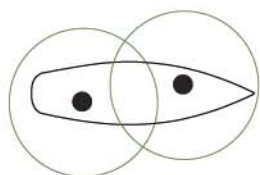

POWER BOAT

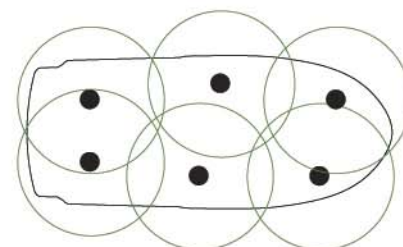
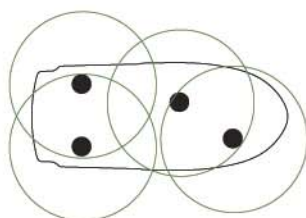
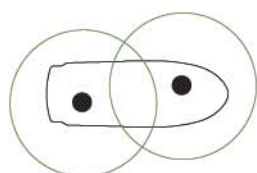

CATAMARAN

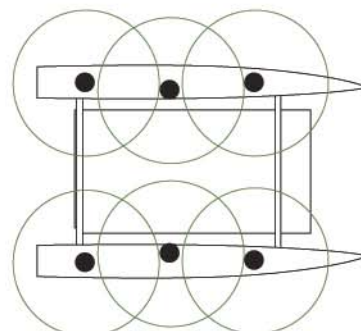
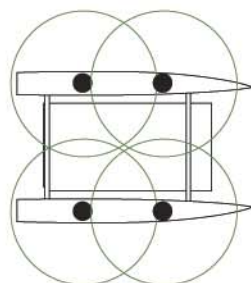
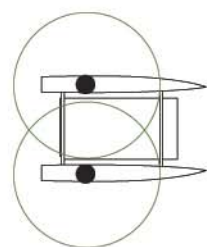

Up to 50ft. (15 metres)
1x Sonihull Duo

50-70ft. (15-21 metres)
2x Sonihull Duo

60-100ft. (18 to 30 metres)
3x Sonihull Duo



TRANSDUCER POSITIONING – FOR BOX COOLERS

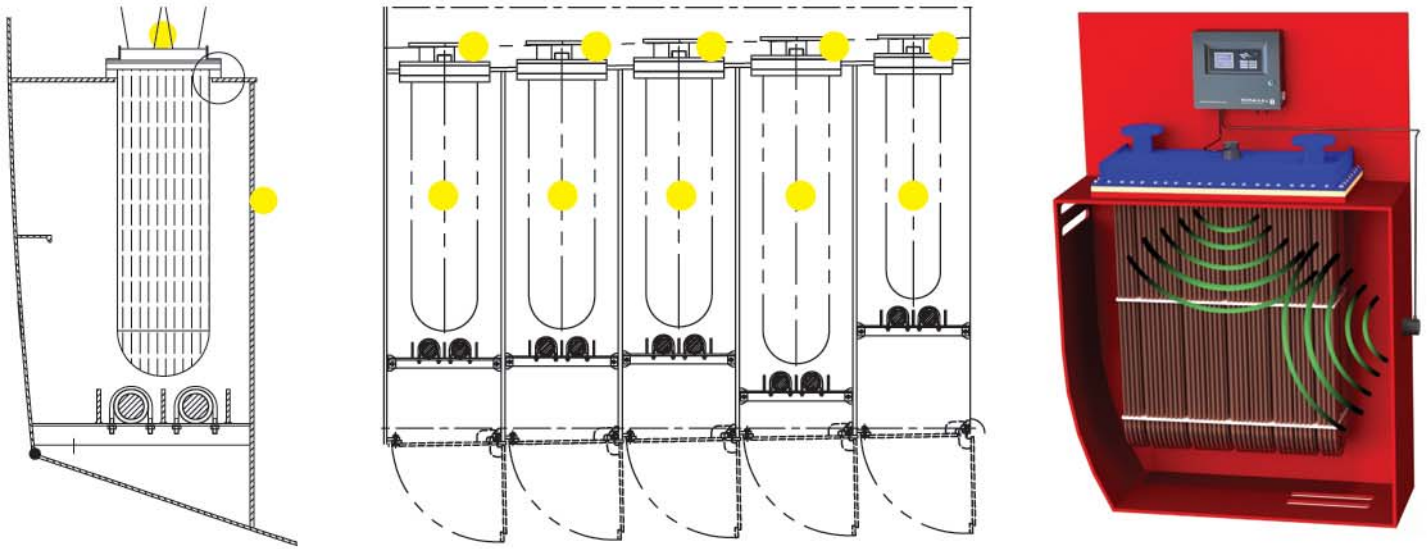

TRANSDUCER POSITIONING – FOR JETDRIVES

Recommended Sonihull transducer locations:

- 1x Transducer located in the centre of the impeller housing
- 1x Transducer located on the intake housing in line with the impeller shaft

*Contact us for specific installation advice if:

- Your vessel is larger than 55 feet
- Your BWL (Beam at the Waterline) is greater than 16 feet
- For larger commercial vessels or inboard equipment (sea chests, box coolers, tanks, pipework, prop-shafts etc...)

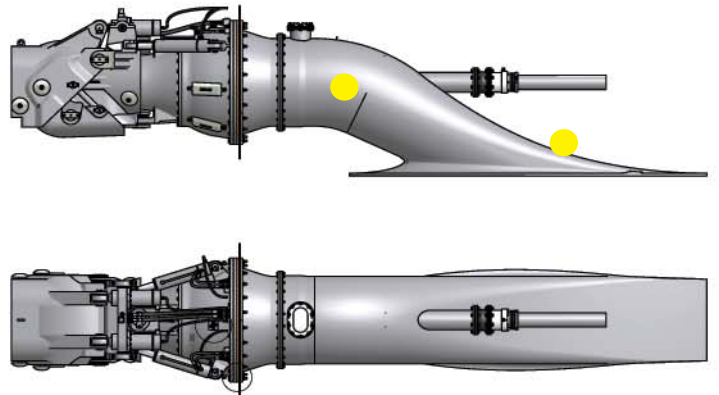

JOB ORDER FOR TYPICAL INSTALLATION

1. Prepare the surfaces where the Sonihull transducers will be located and epoxy down the transducer mounting ring(s) – allow enough time to let the epoxy set. (read pages 7-10)
2. Mount the control box, connect the AC and/or DC power (read page 5)
3. Apply transducer gel and attach transducer(s) (read pages 10-11)
4. Run cable back to control box not forgetting to leave enough cable slack by the transducer so it can be unscrewed for future maintenance.
5. Plug in transducers and switch on.

GUIDE TO FIXING A SONIHULL TRANSDUCER RING TO AN ALUMINIUM OR BARE METAL SURFACE

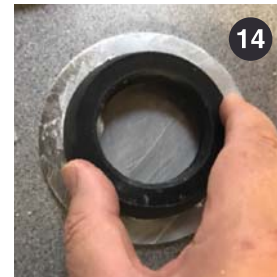
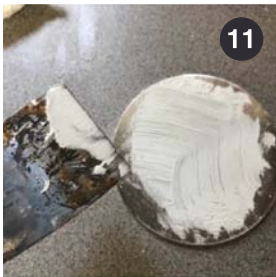
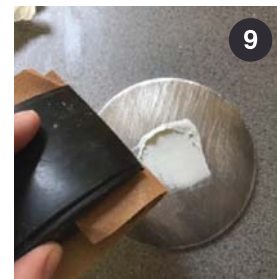
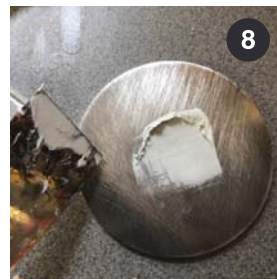
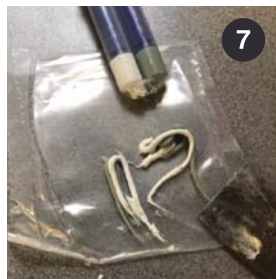
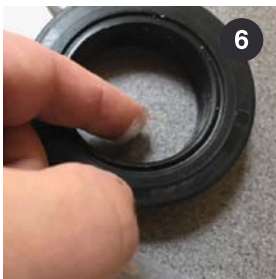
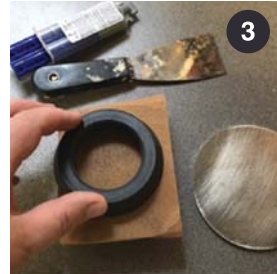

[Photo 3] Key the surface of the aluminium and the mounting ring with 80 grit sandpaper, wipe and clean.

[photo 6] Carefully apply petroleum jelly to the thread to protect against any stray epoxy.

[photos 7 & 10] Mix the 2 part epoxy. Apply a small amount to the aluminium surface and rub in with sandpaper.

[photo 12] Scrape off excess epoxy with scraper.

[photo 13] Apply epoxy to the outer part of the ring surface.

[photo 14 & 15] Press the mounting ring firmly into place, ensuring no epoxy splashes are visible inside the ring or on the thread.

[photo 16] Tape in place and leave to dry for 12-24 hours.

[photo 17] Once dry, apply Vaseline to face of transducer and screw it into place following step 3 of the installation tips on page 10.

SONIHULL

Ultrasonic Anti-foul Protection



SONIHULL TRANSDUCER INSTALLATION

Apply a thin layer of petroleum jelly to the thread of the mounting ring, ensuring to keep the bonding surface of the ring free from any grease (this will stop any epoxy from accidentally getting stuck in the thread).

Prepare the marine epoxy as per the manufacturer's instructions. You will note that a gutter has been incorporated into the design of the mounting ring to help prevent any stray epoxy being squeezed into the thread.

Apply the epoxy to the face of the mounting ring, on the outside of the gutter and press firmly into place. It is important to epoxy the full 'circle' of the transducer to make a complete seal with the hull once set.

Allow the epoxy to set fully prior to attaching the transducer.



ATTACHING THE TRANSDUCER

Prior to screwing in the transducer to the mounting ring, the face of the transducer should be covered with a thin (1mm) layer of petroleum jelly. This will allow better contact between transducer and surface and better transmission of ultrasound.

Screw the transducer fully in to the mounting ring, ensuring that the mounting ring has bonded correctly onto the mounting surface. Do not over tighten as this could cause the epoxy to break.

Run cables back to the Sonihull control unit and connect.

If you have already run the transducer cables, please rotate the transducer anti-clockwise about 8 rotations before screwing it in. This will ensure that the cable is not twisted once the transducer is screwed clockwise into the mounting ring.

Please also read our SONIHULL INSTALLATION TIPS, for more advice about transducer location and installation.



Ensure you leave enough slack cable at the transducer so that it can be unscrewed at a later date.

SONIHULL INSTALLATION TIPS



To get the best performance from the system there are 3 main considerations.

1. LOCATION

For hull fouling protection, the transducer needs to be mounted on an obstruction-free area below the water line and on the inside of the external skin. To enable the transducer to create resonance it must be away from any bulkheads, bracing and ribs etc, ideally in the centre of a panel and not closer than 300mm from any obstruction. Compare this to the skin of a drum. To make the best noise you would hit in the middle, not at the edges, ultrasound transducers need the same consideration.



2. INSTALLING THE TRANSDUCER MOUNTING RING

The transducer needs complete face-to-face contact for good transmission, and that means flat, not curved, bowed or rough. Only flat contact will work. Also, ensure that there are no drips of glue inside the ring. A little pimple of hard glue or weld spatter can hold the transducer off the surface and will prevent correct transmission of ultrasound. If there are any concerns that the surface is not flat, follow the manual for using the aluminium contact disk as a problem solver.



3. APPLYING THE PETROLEUM JELLY

The transducer needs to have a smear of petroleum jelly on the face to ensure correct transmission. An even 1mm application will ensure that good contact can be made. Do not apply too much as the transducer face will not get close to the surface and the signal will be insulated.

As good practice, when you first screw in the transducer, screw it in finger-tight. Then, remove the transducer and observe the swirl marks in the petroleum jelly on the transducer and look for the corresponding wetting on the surface inside the ring. This will give you a clear indication of the quality of the surface contact.

PIPE ADAPTOR INSTALLATION

Find a suitable location for the pipe adaptor, ideally no closer than 250mm to a flange or bulkhead. Take into account accessibility, so the transducer can easily be installed and maintained.

Prepare the pipe by sanding to remove any surface paint and to create a key for epoxy glue to bond with. Apply epoxy glue to the curved surface of the pipe adaptor, paying attention to the Center of the curve, ensuring there are no air bubbles.

Press the adaptor on to the pipe firmly so that the epoxy glue spreads evenly. Hold The pipe adaptor in place so the epoxy glue can dry without the adaptor moving. The locating grooves are ideal for holding in place with Zip-tie or jubilee clips.

Apply 1-2mm of Vaseline across the face of the transducer.

Holding the pipe adaptor so it can't move, screw in the transducer fully into the adaptor. The transducer should be tightened to ensure good contact, but not over tightened.



MOUNTING TRANSDUCERS IN CURVED OR ROUGH LOCATIONS



USING THE ALUMINIUM CONTACT DISK

The purpose of the aluminium contact disk is to create a flat surface for the transducer to transmit through, by pressing the epoxy on its underside into the gaps & creating a solid contact with the mounting surface.

1. Ensure that the mounting rings are firmly mounted and that the epoxy has cured fully (to prevent the ring coming off once the transducer is screwed into the ring).
2. In preparation for a later stage, apply a very thin layer of petroleum jelly across the face of the transducer.
3. Remove the protective plastic sheet from both sides of the aluminium disk.
4. Depending on how rough or curved the surface inside the mounting ring is, apply a suitably sized quantity of epoxy on the centre of the aluminium disk.
5. Insert the disk into the mounting ring with the epoxy side touching the mounting surface. Screw in the transducer so that the face of the transducer will push down on the disk, which in turn will spread the epoxy evenly across the surface of the disk.
6. Allow the epoxy to cure before switching on the Sonihull.

Should you require any further information or technical assistance please email us at: info@nrgmarine.com.

MONITORING OUTPUT CONNECTION

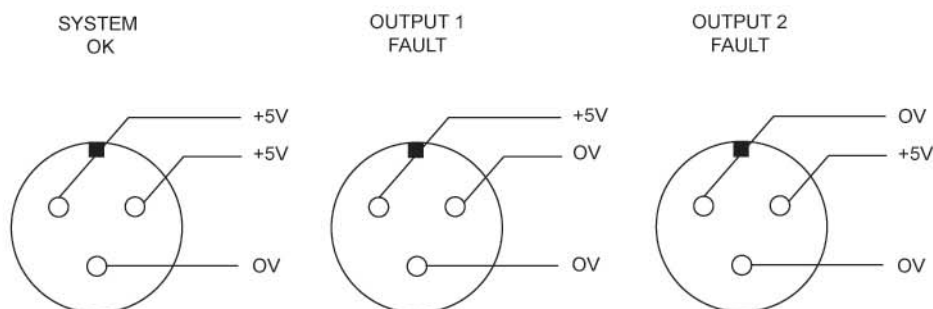

Sonihull monitoring outputs via the 3-pin micro XLR connector on the control panel.

The system is monitoring the full critical path of each of the Sonihull channels, through to the transducer. In normal operation the Green output LEDs and the GREEN Healthy LED will be ON.

The output for each channel will be +5 Volts.

Under a fault condition, the relevant channel LED and the Healthy LED will be OFF.

In Healthy condition, the output for the faulty channel will drop to 0 Volts.

For further information contact us at: info@nrgmarine.com

SONIHULL ACCESSORIES

Ensure you have all the surface-mounting adaptors you need to protect all your equipment against marine biofouling

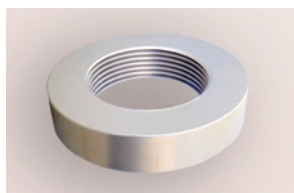

ALUMINIUM MOUNTING RING

Marine grade weldable aluminium is ideal for a wide range of aluminium vessels, jet drives, sea chests and other aluminium marine structures. Ideal for new builds where the rings can be fitted as part of the standard build where Sonihull is offered as a buyer option.



STERN DRIVE ADAPTOR

This bolt-on device allows ultrasonic transmission into surfaces that are hard to reach, like stern drive. Results show an impressive average of 80% reduction in fouling on stern drives using Sonihull via a stern drive adaptor.



SONISHAFT

This universal vibration-absorbing mount enables Sonihull's ultrasonic antifouling pulses to be transmitted directly into a rotating prop shaft and along through to the propeller. A clean prop can reduce fuel consumption by 20%.

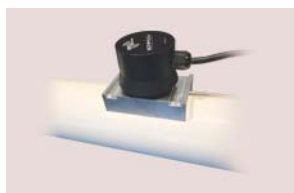

PIPE ADAPTOR

With a wide range of standard-diameter pipe adaptors, Sonihull can be attached to almost any kind of pipework. Protecting valves, inlets, sea chests, box coolers, keel coolers and heat exchangers from being clogged by marine growth.

SONIHULL - THE FUTURE OF ANTIFOULING, NOW

Fouling on your hull and props can increase fuel consumption by up to 30% and, in raw water pipes, fouling will block cooling systems and cause premature equipment failure.

NRG Marine's Sonihull ultrasonic antifouling system is complete range of fit-and-forget antifouling solutions for any solid surface that is exposed to raw seawater. With a wide range of surface-mounting adaptors, Sonihull can now protect every part of your vessel from marine fouling, from hulls, shafts, propellers and waterjets, to sea-chests, tanks, keel-coolers, box-coolers, pipework, intakes and valves.

For decades, ultrasound has been used in the food, brewing and hydroponic farming industries to prevent algal blooms and to keep water-handling equipment clean and free from blockages. By focusing the same technology into marine applications, Sonihull has become an effective antifouling solution. Unlike biocidal coatings and impressed-current systems, Sonihull is low cost, low maintenance and has zero poisonous environmental legacy.

Sonihull systems produce multiple bursts of ultrasonic energy in a range of targeted pulse frequencies. These pulses are transmitted through the material that the transducer is attached to, producing a pattern of alternating positive and negative pressure on the surface of the material. Microscopic bubbles are created during the negative pressure cycle and are imploded during the positive pressure cycle.

This microscopic agitation has a cleansing effect which destroys surface algae. Disrupting this first link in the food chain keeps the surface clean and makes it a much less inviting habitat for larger organisms that feed on the algae. The microscopic movement of water also prevents barnacle and mussel larvae from embedding on the surface.

SONIHULL

Ultrasonic Anti-foul Protection



Lamers System Care
Loopkantstraat 25
5405 AC Uden
The Netherlands
+31 413 275 647
info@LSCare.nl
www.LSCare.nl

